

Varistor Type MYG

Features

- Wide Varistor voltage range (18V ~ 1800V)
- Excellent non-linearity and protection level
- Large withstanding surge current
- Fast response ($\leq 20\text{ns}$)

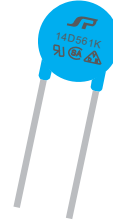

Applications

- Protection of semiconductors
- Surge protection of consumer equipment
- Surge protection of communication, measuring or controller instrument
- Relay or electromagnetic Valve surge absorption

Explanation of Part Numbers

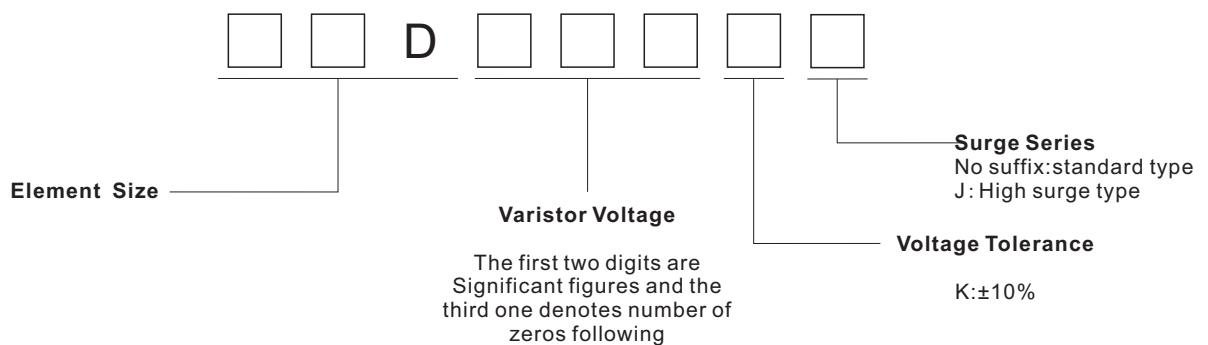

Dimension

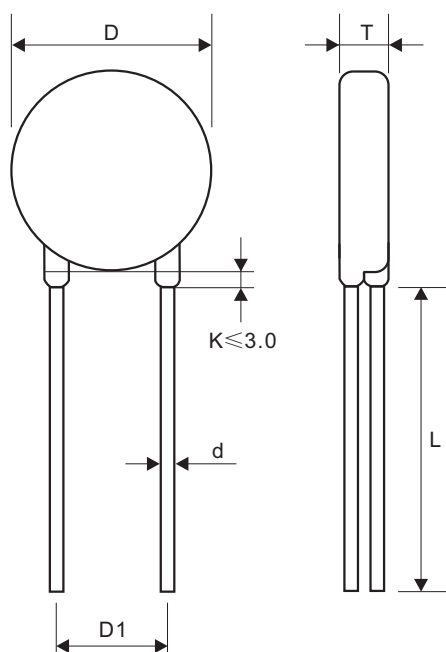

Rang of voltage (V)	Dimensions(mm)				
	D max	T max	L min	$d \pm 0.1$	$D1 \pm 1.0$
18-68	17.0	4.0-6.0	25	0.8	7.5
82-1800	16.5	4.4-15.2	25	0.8	7.5

Electrical Characteristics

Part Number		Maximum Allowable Voltage		Max Peak Current (8/20 μ s)(A)		Rated Power	Maximum Energy 10/1000 μ s (J)		Varistor Voltage	Maximum Clamping Voltage		Typical Capacitance (Reference)
Standard	High Surge	V _{AC} (V)	V _{DC} (V)	Standard	High Surge	W	Standard	High Surge	V _{1mA} (V)	V _C (V)	I _P (A)	@1KHz(pF)
14D182K	14D182KJ	1000	1465	4500	6000	0.6	354	510	1800(1620-1980)	2970	50	100
14D112K	14D112KJ	680	895				213	310	1100(990-1210)	1815	50	150
14D102K	14D102KJ	625	825				190	280	1000(900-1100)	1650	50	150
14D911K	14D911KJ	550	745				175	255	910(819-1001)	1500	50	180
14D821K	14D821KJ	510	670				157	230	820(738-902)	1355	50	200
14D781K	14D781KJ	485	640				150	210	780(702-858)	1290	50	230
14D751K	14D751KJ	460	615				143	210	750(675-825)	1240	50	230
14D681K	14D681KJ	420	560				130	190	680(612-748)	1120	50	250
14D621K	14D621KJ	385	505				125	190	620(558-682)	1025	50	250
14D561K	14D561KJ	350	460				125	190	560(504-616)	925	50	300
14D511K	14D511KJ	320	415				125	190	510(459-561)	845	50	350
14D471K	14D471KJ	300	385				125	175	470(423-517)	775	50	400
14D431K	14D431KJ	275	350				115	155	430(387-473)	710	50	450
14D391K	14D391KJ	250	320				100	140	390(351-429)	650	50	500
14D361K	14D361KJ	230	300				93	130	360(324-396)	595	50	550
14D331K	14D331KJ	210	275				85	115	330(297-363)	550	50	650
14D301K	14D301KJ	190	250				78	108	300(270-330)	500	50	700
14D271K	14D271KJ	175	225				70	99	270(243-297)	455	50	750
14D241K	14D241KJ	150	200				63	84	240(216-264)	395	50	900
14D221K	14D221KJ	140	180				60	78	220(198-242)	360	50	1000
14D201K	14D201KJ	130	170				57	70	200(180-220)	340	50	1000
14D181K	14D181KJ	115	150				52	62	180(162-198)	300	50	1100
14D151K	14D151KJ	95	125				40	53	150(135-165)	250	50	1500
14D121K	14D121KJ	75	100				32	42	120(108-132)	200	50	1900
14D101K	14D101KJ	60	85				28	35	100(90-110)	165	50	2400
14D820K	14D820KJ	50	65				22	28	82(74-90)	135	50	2900
14D680K	14D680KJ	40	56	1000	2000	0.1	14	20	68(61-75)	135	10	3300
14D560K	14D560KJ	35	45				11	16	56(50-62)	110	10	4400
14D470K	14D470KJ	30	38				10	14	47(42-52)	93	10	5200
14D390K	14D390KJ	25	31				8.6	11	39(35-43)	77	10	6400
14D330K	14D330KJ	20	26				7.5	9.5	33(30-36)	65	10	7200
14D270K	14D270KJ	17	22				6.0	7.8	27(24-30)	53	10	9500
14D220K	14D220KJ	14	18				5.0	6.3	22(20-24)	43	10	14000
14D180K	14D180KJ	11	14				4.0	5.2	18(15-21)	36	10	17000

Note: 1. Operating Temperature Range: -40 $^{\circ}$ C ~ +85 $^{\circ}$ C
 Storage Temperature Range: -40 $^{\circ}$ C ~ +125 $^{\circ}$ C